



ICEPRO

OWNER'S MANUAL
2024



ICEPRO

Thank you for choosing the IcePro fish house. We are confident that your IcePro will bring you countless enjoyable years of ice fishing.

This guide has been crafted to equip you with comprehensive information for your upcoming ice fishing experiences. For additional assistance and informative videos, feel free to explore iceprotrailers.com.

This manual is written to encompass all the features and equipment offered within the IcePro range. Please note that some of these features may not be applicable to your specific layout or selected options.



Table of Contents

1

CUSTOMER APPRECIATION

2

TABLE OF CONTENTS

3

PREPARING FOR TRAVEL

4

TRAILER HITCH HOOK UP

4-5

BATTERY CARE/ ELECTRICAL SYSTEM

5-6

FUSES

7

LP SYSTEM

8

EQUIPMENT OPERATION

8-9

MAINTENANCE AND CLEANING

9-10

STORAGE & SPRING/FALL CHECKLISTS

10-11

SPECIFICATIONS & SAFETY PRECAUTIONS

11

HEIGHTS & WEIGHTS

11-13

TROUBLESHOOTING

14-16

ICE PRO INSTRUCTIONS - RUNNING GEAR

Preparing for Travel

Packing Your Trailer

When packing the trailer, weight distribution should always be kept in mind. Improper distribution may cause the trailer to sway or bounce.

Pack items so that they will not migrate or slide around while on the road. Breakable items should be packed securely where they cannot fall or shift. Heavy items should be placed on the floor, over the axle or slightly forward of the axle.

An old rule of thumb is 40% behind the axle and 60% in front. IF MOVING WEIGHT FURTHER FORWARD, BE AWARE THAT THIS MAY INCREASE THE OVERALL TONGUE WEIGHT OF THE TRAILER.

Before You Tow:

- Close and lock all windows
- Close all interior doors
- Check that all caps and vent covers are closed and secure
- Close the doors and lock the dead bolt
- Secure Chairs (if applicable)
- Check Tire Pressure (Set 6 ply tires to 50 psi., 8 ply tires to 68 psi.)

2" Ball - Recommend Ball Height

(top of ball to ground)

17' = 21"

ideal for level height

Trailer Hitch Hook Up

1. Lift the latch lever and lower the coupler onto the ball. While closing the latch, check that the locking under-jaw clamps securely beneath the ball. If the under-jaw is sliding over the ball, raise the coupler and try again. Once secure, raise the tongue jack until completely retracted.
2. Attach (and cross) the tow chains to the hitch eyelets. Ensure the chains will not drag on the ground.
3. Plug the 7-Way electrical connector into the tow vehicle receptacle.
4. The trailer should ideally be level once hooked up. If it is not level you may need to install a different hitch.

NOTE: When unhooking, sometimes the trailer is too far forward or backward for the coupler to release. If this happens, move the vehicle slightly forward or back.

Check Your Trailer Lights

Verify all driving lights are functioning. Check right signal, left signal, brake and side marker lights.

Electrical System

Battery Disconnect

The battery disconnect switch can be used to isolate the battery from the rest of the electrical system. This is convenient if you are storing the trailer for a few weeks as it will prevent the onboard utilities from drawing down your battery. The disconnect does not interrupt power between battery & charging source.

*** Please Note:** The disconnect switch can be used to isolate the trailer from all power sources. This is a convenient way to ensure your battery is not drained by on board utilities.

Shore Power

Your trailer is equipped with a 30 amp RV plug called the "Shore Power" hook-up. This can be plugged into a 120V AC, 30 amp service (available at most campsites) or an appropriately sized generator. You can also plug the shore power into a household 15 amp outlet, using the included adapter.

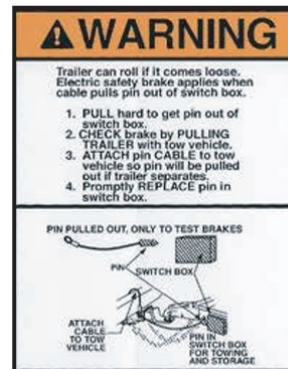
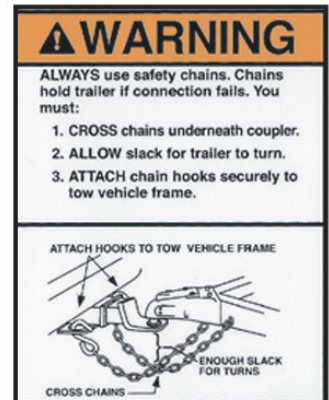
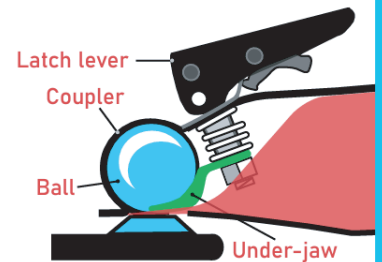

The 12V DC System/House Battery

Most electrical utilities on your trailer are designed to run on 12V DC (battery). The 12V system is versatile but can only provide power to smaller fixtures and appliances. It will not provide power to the interior household style outlets. Each of the 12V fixtures and appliances can be powered by the onboard house battery as well as a number of different sources including:

- Your Shore Power hook-up
- Solar array*
- Tow vehicle**
- 12V generator/charger
- 120V generator via shore power hook up

When any of the of these sources are connected, they will also begin charging your house battery.

*Dependent on power consumption, size of solar array and available sunlight.

**Dependent on the tow vehicle wiring and how much power the specific tow vehicle is able to produce.

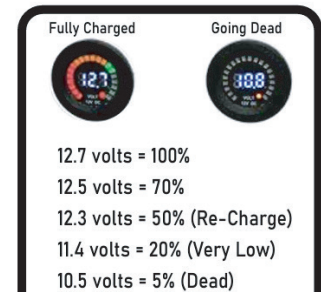

Battery Charging

Your trailer has an onboard voltmeter (shown on the right) to aid in determining the battery state of charge. A fully charged battery will have a resting voltage of 12.6V to 12.8V. If there is a load on the battery, it is normal that the voltmeter may display a lower voltage. The battery is generally considered discharged when it reaches 10.5V. Fully discharging may reduce the service life of the battery. For maximum service life, keep the battery topped off as often as possible. If the voltage drops below 10.8V, some onboard equipment such as the furnace, roof fan or refrigerator may cease to function properly. When charging the battery via Shore Power, the onboard charger will deliver between 13.6V and 14.4V. Once the battery is fully charged, the charger will dial down to a 13.2V float voltage. When charging from your tow vehicle or other external sources, the voltage should be at least 13.6V to provide a sufficient charge to the battery.

Fuse & Breaker Panel

Your fuse and breaker panel is mounted on the face of the passenger-side bench.

Breakers in Panel (120V)

1. 30a – 120V Main
2. 15a – Converter/Outlets

Fuses in Panel (12V)

1. 10a – Lights
2. 15a – 12 Volt Outlet
3. 10a – Furnace
5. 15a – Utilities

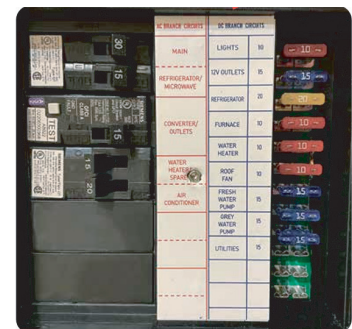

50 Amp Self - Reset

This is a separate battery fuse from the one in your panel, it is located inline at the positive battery terminal. Open your battery box cover to access this fuse.

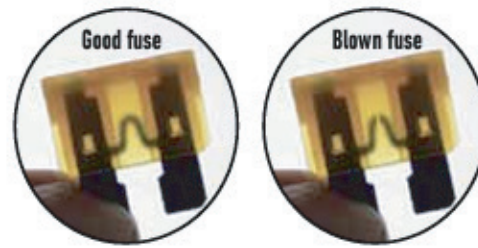

30 Amp Converter Fuses

These two fuses are located on the side of the converter housing. The converter is mounted inside the driver side rear bench. All 12V fuses are standard ATO/ATC fuses. Fuses can blow for a variety of reasons including wiring faults, load spikes (generally from connecting or disconnecting a power source) or defective fuses. Always have spare fuses available.

To see if a fuse is good or bad, look at the filament between the contacts. If this filament is burnt or broken, the fuse has blown and needs to be replaced. A fuse can sometimes appear **good and still be faulty**. If there is any question, try swapping the fuse out to verify that it is indeed working. Since fuses are considered regular maintenance items, the trailer warranty does not cover fuses or service charges that determine a bad or blown fuse to be source of a failure.

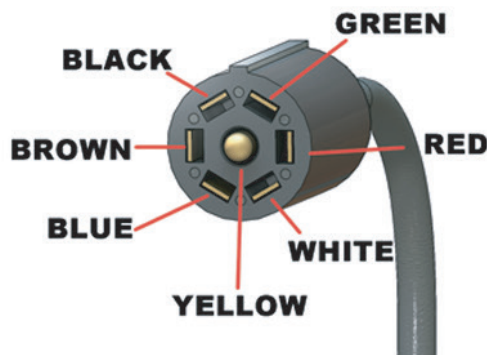

Trailer End

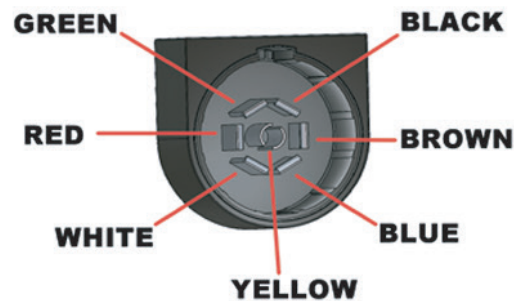

Vehicle End

Electrical Connectors

- Green Wire-Tail Lights/Marker Lights
- Brown Wire- Right Turn and Brake Light
- White Wire-Ground
- Blue Wire- Electric Brakes
- Red Wire-Left Turn and Brake Light
- BLACK WIRE-POSITIVE (CHARGE/HOT LINE)
- Yellow Wire- Auxiliary (Back Up Lights)

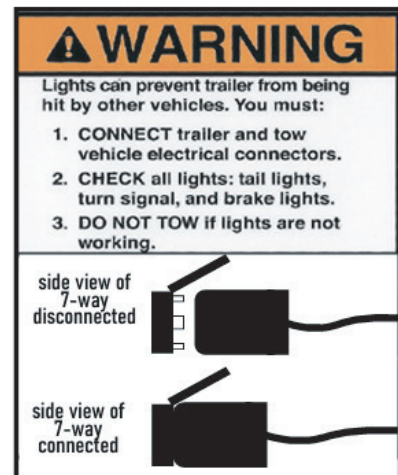

LP System

Your trailer is equipped with dual propane tanks. These tanks are 20lb liquid propane cylinders. We selected this tank style because it is the most readily available and most easily exchanged or refilled. To use the propane system, the gas must first be turned on at the tank. Initially, the lines may still be filled with air.

Dual Tanks

If you purchased the dual tank system there will be a switchover regulator. This regulator draws from one tank at a time. There is a green indicator on this regulator that will turn red as the last tank begins to run empty. You will then know to switch over to the other tank.

All IcePros have a CO₂/PROPANE GAS DETECTOR to alert you of a dangerous situation. It is normal to briefly smell the propane when you first light an appliance. Apart from this exception, you should never be able to smell propane gas inside the trailer.



⚠ DANGER

IF YOU SMELL PROPANE:

1. Extinguish any open flames and all smoking materials.
2. Shut off the propane supply at the container valve(s) or propane supply connection.
3. Do not touch electrical switches.
4. Open doors and other ventilating openings.
5. Leave the area until the odor clears.
6. Have the propane system checked and leakage source corrected before using again.

Ignition of flammable vapors could lead to a fire or explosion and result in death or serious injury.

Equipment Operation and Use

Entry Door Lock

The door has two lock cylinders. One for the paddle handle and one for the deadbolt.

To lock the paddle handle: Insert the key. Turn counterclockwise 1/4 turn until key is horizontal, remove key.

To unlock the paddle handle: Insert the key. Turn clockwise 1/4 turn until key is vertical, remove key.

To lock the deadbolt: Insert the key, turn counterclockwise 1/4 turn until the key is horizontal, then turn back until the key is vertical, remove the key.

To unlock the deadbolt: Insert the key, turn clockwise 1/4 turn until the key is horizontal, then turn back

NOTE: To use any propane appliance you must first let gas into the lines by turning the tank valve handle counter clockwise.

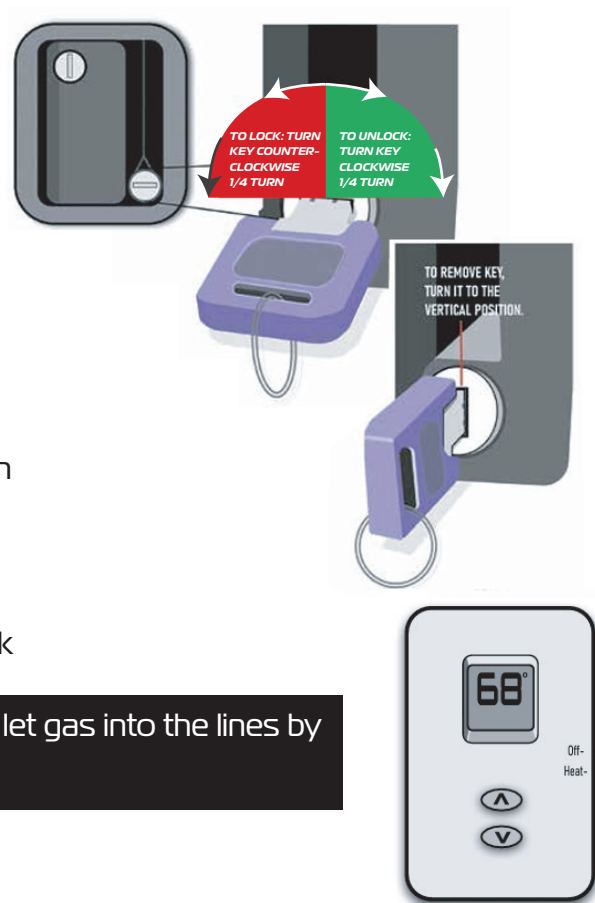

Furnace

Set the thermostat switch to HEAT.

Set the desired temperature using the up and down arrows. If the selected temperature is greater than the ambient temperature, the furnace will start. If the trailer is very cold, the furnace may overshoot the first cycles. Once the trailer interior begins to warm the temperature will balance out.

Maintenance and Cleaning

Battery Upkeep

The house battery is a wet cell battery and the water level will need to be maintained periodically. How often will depend on battery use and ambient temperatures. Proper safety precautions must be taken when working with the battery. It is recommended that this service be performed by a qualified service technician.

Terminals and Connectors

Regularly inspect all electrical contacts, eyelets, terminals and connectors for corrosion or wear which may degrade the electrical connection and lead to electrical malfunctions.

Axle Bearings

Bearings should be lubed every 5000 miles and visually inspected every 10,000 miles.

Lubrication

Remove the rubber cap from the middle of the grease cover on the end of the spindle. Attach your grease gun fitting to the zerk and add grease. Two or three pumps is generally sufficient. It is recommended that the grease be added slowly while rotating the tire. This will reduce the risk of pushing through the grease seal.

Visual Inspection

Remove dust cap, cotter key, and castle nut. Slowly slide the hub from the spindle. Clean the interior cavity of the hub. Remove bearings from spindle clean and remove old grease from bearings. Visually inspect hub cavity and bearings for discoloration, damage, pitting, or flat spots, and check rolling functionality. Replace parts if needed. Hand pack new grease into the bearings and re-assemble. Add 5 extra pumps (for manual grease gun) or about a thimble sized amount of grease into the chamber.

Sealants

Inspect all sealant annually around your windows, appliances, doors and vents. If the sealant is damaged, replace immediately. Failure to maintain sealant can lead to serious damage to your trailer with leaking issues.

General Cleaning Information

Windows

Window and glass cleaners.

Fiberglass/Gelcoat

Window cleaners or multi-purpose cleaners. Auto or Marine wax and body wax

Storage

Moisture Levels

Humidity can be an important factor depending on your climate. Left unchecked, humid air inside the trailer can condense resulting in water damage, mold and warping. In humid areas, the use of either an absorbent or powered dehumidifier is recommended.

Battery Storage

The trailer battery should not be left outside in freezing weather for a prolonged period. Doing so may freeze the electrolyte and destroy the battery. Store the battery in a heated space or use a battery maintainer/trickle charger to keep the battery charged and prevent freezing.

Spring Checklist

1. Battery: Charge your battery, then hook it back up to your trailer.
2. Appliances: Check the gas supply, check the operation of all LP fired appliances. Do a leak test and LP gas operation pressure test annually.
3. Tires: Check your air pressure. Inspect tires for any cracks, foreign objects.
4. Seams and sealants: Inspect seams and sealants for any cracking or separation, reseal if needed.
5. Replace batteries in thermostat, remotes, and check fire extinguishers that they are fully charged

Fall Checklist

1. Battery: Charge your battery, then hook it back up to your trailer.
2. Appliances: Check the gas supply, check the operation of all LP fired appliances. Do a leak test and LP gas operation pressure test annually.
3. Tires: Check your air pressure. Inspect tires for any cracks, foreign objects.
4. Seams and sealants: Inspect seams and sealants for any cracking or separation, reseal if needed.
5. Replace batteries in thermostat, remotes, and check fire extinguishers that they are fully charged

Specifications

120v Outlets - Rated for 15amp service

12v Sockets - Rated for 10amp service

Group 27 Battery - 66AH - 955 ca/650 cca - 160 min Reserve Capacity

Wheel Lug Nut Torque - 90 ft lbs

Wheel Lug Nut Wrench Size - 13/16"

Tire Pressure 6 ply, Load C - 50psi Max



Ball Height

(average height to top of ball)

IcePro - 21"

Cargo Weight*

Cargo Weight*: Please refer to the label on your trailer for your cargo weight. *weight may vary due to trailer options. ▶

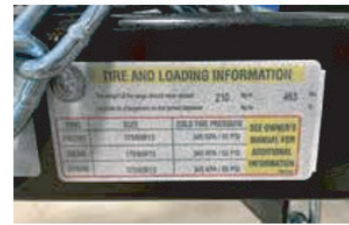

NOTE: Never exceed your tow vehicle's maximum towing capacity!

Safety Precautions

At IcePro Trailers, nothing is more important to us than your safety. This includes driving/towing safety, occupant safety, operational safety, and more. When you are dealing with carbon monoxide producing appliances, propane gas, electricity, it is critical that safety become your number one priority in and around your IcePro Trailer.

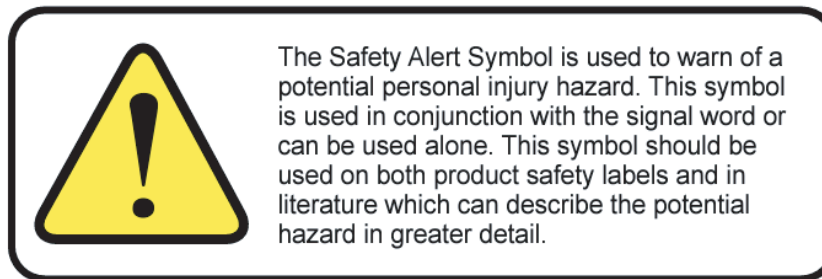

Troubleshooting

<i>Problem</i>	<i>Possible Cause</i>	<i>Solution</i>
Loss of 12v Power from Battery	Disconnect switch is turned OFF	Turn switch ON
	Low Battery	Charge Battery
	Blown 12v Fuse (see Breakers and Fuses page 5)	Replace Fuse
	Loose or corroded wiring connection	Secure wiring. Clean or replace any corroded terminals
Loss of 12v power or charge from Shore Power Hookup	Blown 12v Fuse (See Breakers and Fuses page 5)	Replace Fuse
	Converter power cable unplugged.	Plug into adjacent outlet/plug into converter
Loss of 12v power or charge from Tow Vehicle	Blown 12v fuse (see Breakers and Fuses page 5)	Replace Fuse
	7 way connector is loose, dirty or faulty	Re-seat, clean or replace connector
	Inadequate wiring/power output from Tow Vehicle	Have vehicle tested.

Troubleshooting (continued)

Problem	Possible Cause	Solution
Battery loses charge quickly	Loose or corroded wiring connection to battery	Secure terminals, clean or replace any corroded connectors
	Tow vehicle wiring is not properly isolated and intermittently draws power from battery	Service tow vehicle
	Battery is not reaching a complete charge before each use. (12.6V to 12.8V)	Check charge source: Charge voltage should be 13.6V to 14.4V. The lower voltage takes more time to charge.
	High power consumption or power drain	Unplug any high consumption 12V aftermarket accessories. Check for other power drain: breakaway switch engaged.
	Battery has reached end of service life or has been drained too far and is damaged	Replace battery
Battery fuse or Main fuse blows when connected to Tow Vehicle	High power consumption or power drain	Unplug any high consumption 12V aftermarket accessories. Check for other power drain: breakaway switch engaged.
	Battery was let drain too far before charging which creates high load	Use separate charger to begin charging or use shore power
	Tow vehicle wiring is not properly isolated and intermittently draws power from battery	Service tow vehicle
Co2/LP Detector beep (not alarm)	Low Battery	Charge Battery or use shore power
	"End of service life" indicator	Replace Detector

Troubleshooting (continued)

Problem	Possible Cause	Solution
Battery does not charge	Disconnect switch is turned OFF	Turn switch ON (vertical)
	Blown 12V fuse (see Breakers and Fuses page 5)	Replace Fuse
	Charge source is not operating correctly	Check charge source: Charge voltage should be 13.6V to 14.4V. The lower voltage takes more time to charge
Brakes are locking	Brake control is set too high	Lower Setting*
	Brake control is out of calibration	Re-calibrate Controller
	Breakaway switch plunger has been pulled loose	Re-seat plunger
	Brake mechanism is out of adjustment	Have brakes serviced

** If you are having any Autowbrake system issues please call 319-521-2310. For FAQs and more info: <https://getautowbrake.com> * Note: To disable brakes, follow the 7-way wire into the interior of the trailer, pull the fuse in the brake box (see page 4). This will disable the braking system, while maintaining the trailer lights connection.*

IMPORTANT LINKS TO HAVE

(for specific manufacturer's operation information and manuals)

Suburban Furnace: www.airxcel.com

Honeywell Thermostat: www.honeywellhome.com/us/en/products/air/thermostats/

Progressive Dynamics converters/fuses: www.progressivedyn.com

Lippert Windows: www.lcil.com

Lippert Axle: www.lcil.com/manufacturing/axles

ICE PRO INSTRUCTIONS RUNNING GEAR

1. Lowering the running gear **COUPLED**:

- a. Lowering the tongue: **ALWAYS lower the tongue FIRST.**
 - i. Adjust the jack to align the jack and lower tongue tube hole to place the jack pin as shown in Figure A.
 - ii. Once the holes are aligned, pull the jack pin, and place it in the holes you aligned in the previous step. (Figure B-C).
 - iii. When the jack pin is relocated, we can then retract the jack to relieve the pressure off the hitch pin as shown on Figure C.
 - iv. Once the hitch pin is removed, extend the jack until the tongue is on the ground. (Figure D)

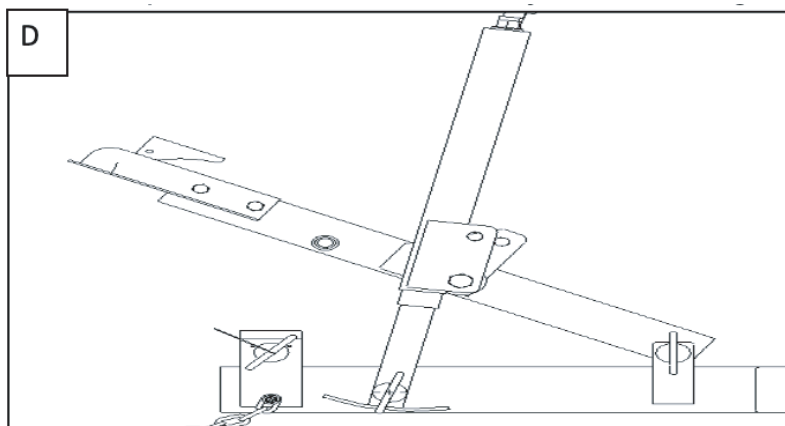
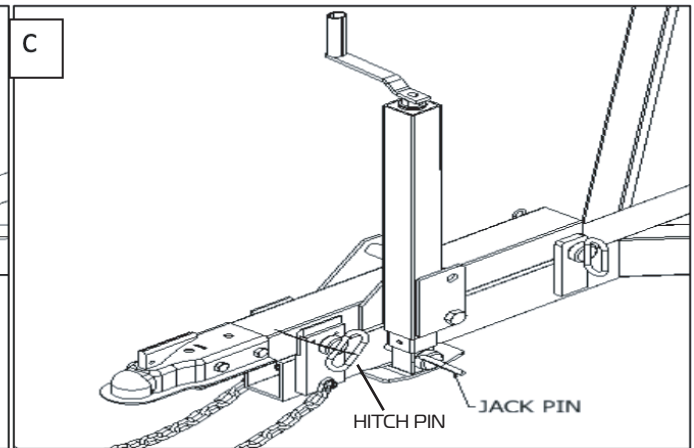
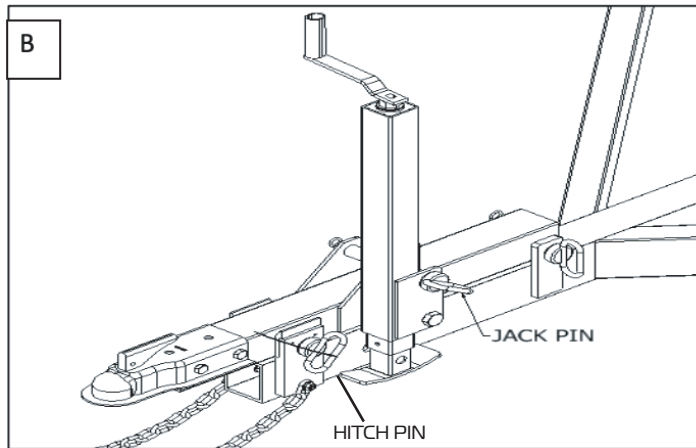
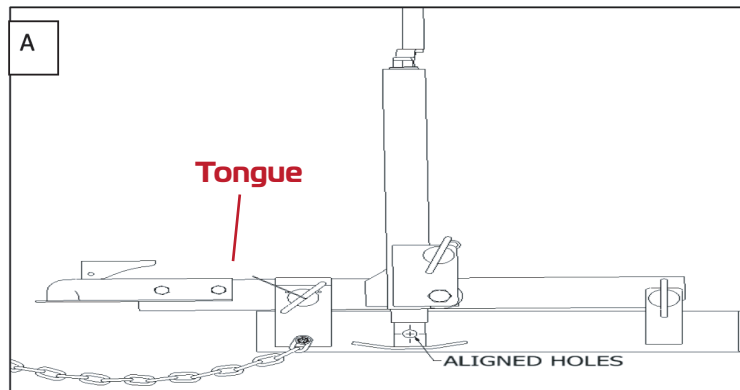

⚠ WARNING

Uncoupling will cause trailer to come loose from tow vehicle. You must:

1. CHECK that ball **LOAD RATING** is same as or greater than coupler **LOAD RATING**.
2. CHECK that ball **SIZE** is same as coupler.
3. **CLOSE COUPLER CLAMP** on ball.
4. **LIFT** coupler upwards to test that it will not separate from ball.
5. **LOCK** coupler clamp with pin or padlock.

© 2002 NATM

⚠ WARNING

ALWAYS use safety chains. Chains hold trailer if connection fails. You must:

1. **CROSS** chains underneath coupler.
2. **ALLOW** slack for trailer to turn.
3. **ATTACH** chain hooks securely to tow vehicle frame.

ATTACH HOOKS TO TOW VEHICLE FRAME

ENOUGH SLACK FOR TURNS

CROSS CHAINS

b. Lowering the wheels:

- i. Once the tongue is lowered, we can then proceed to lower the main frame.
- ii. To lower the wheels, we need to apply tension to the rope to relieve the pressure from the pin shown in Figure E.
- iii. Once the pin is removed, we can then flip the pawl (Figure E) while your hand is on the crank handle and start to slowly crank the frame towards the ground.

*****IF YOU LOSE CONTROL OF THE HANDLE, NEVER ATTEMPT TO OBTAIN CONTROL OF THE HANDLE.*****

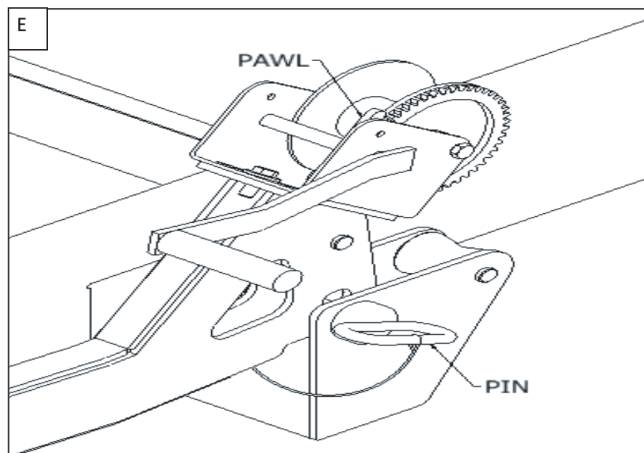

2. Raising the running gear **COUPLED**:

a. Raising the wheels:

- i. To raise the wheels, you need to crank the winch up until the pin holes align.
- ii. Once the holes line up, you can place the pin through the holes.
- iii. Next is to release the pressure off the winch by flipping the pawl and backing it off. Once the pressure is on the pin, remember to flip the pawl back over as a precautionary measure.

b. Raising the tongue: **ALWAYS raise the tongue LAST.**

- i. Raising the tongue is the reverse of how you lowered it.
- ii. Retract the jack until the hitch pin holes line up.
- iii. Once the hole is lined up you can then place the hitch pin.
- iv. Next is to remove the jack pin and place it back to its original place.
"Figure C" to "Figure B"

3. Lowering the running gear **UNCOUPLED**:

a. Lowering the tongue: **ALWAYS lower the tongue FIRST.**

- i. Remove unit from the vehicle by extending the jack without the use of the drop leg.
- ii. Once it is on the ground, retract the jack until the tongue is on the ground.

b. Lowering the wheels:

- i. Once the tongue is lowered, we can then proceed to lower the wheels.
- ii. To lower the wheels, we need to apply tension to the rope to relieve the pressure from the pin shown in Figure E.
- iii. Once the pin is removed, we can then flip the pawl (Figure E) while your hand is on the crank handle and start to slowly crank the frame towards the ground.

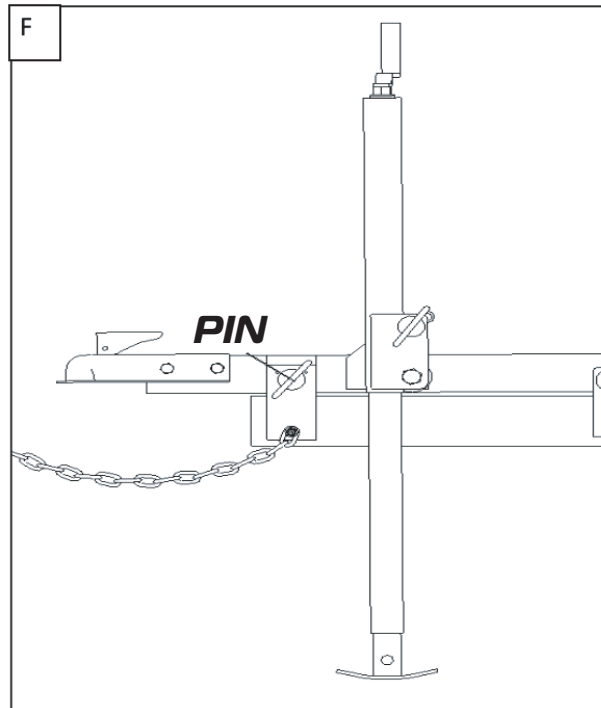

4. Raising the running gear **UNCOUPLED**:

a. Raising the wheels:

- i. To raise the wheels, you need to crank the winch up until the pin holes align.
- ii. Once the holes line up, you can place the pin through the holes.
- iii. Next is to release the pressure off the winch by flipping the pawl and backing it off. Once the pressure is on the pin, remember to flip the pawl back over as a precautionary measure.

b. Raising the tongue: **ALWAYS raise the tongue LAST.**

- i. Raising the tongue is the reverse of how you lowered it.
- ii. Extend the jack until it is coupled to the vehicle.
- iii. Once it is attached to the vehicle, retract the jack completely.